



150
LM/W

“

The best Osram driver and Cree led are used for Slim Generation 2 series flood light. With strict quality control, 5 years warranty is offered. And lumen maintenance after 5 years will be more than 80%

”



150
lm/w

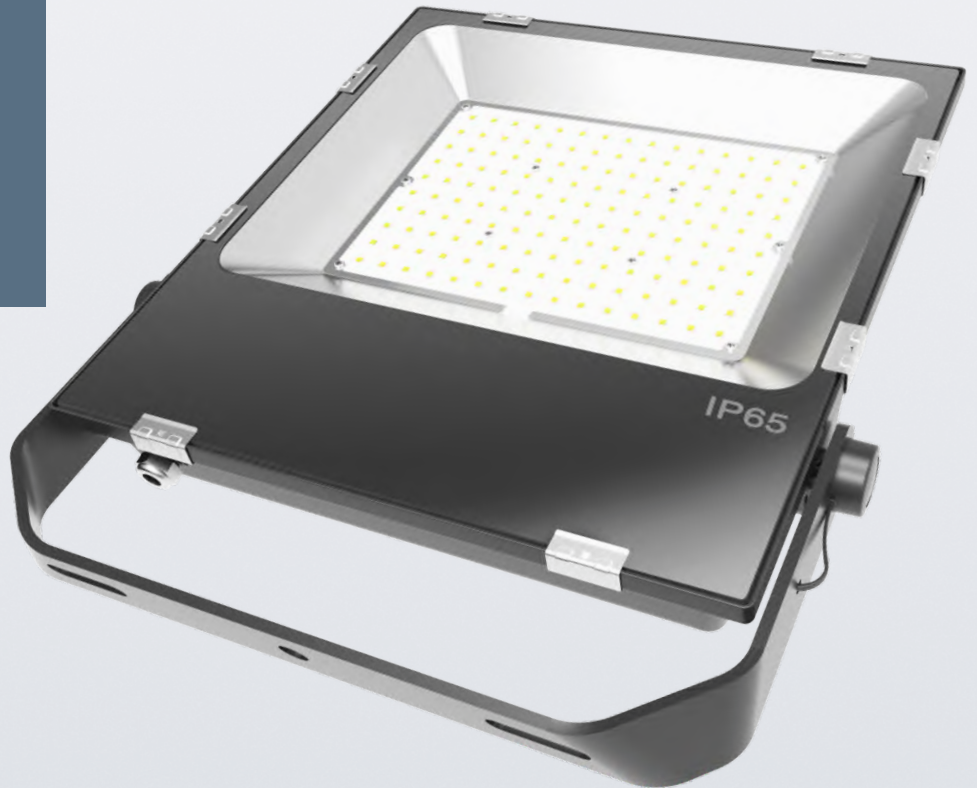

The best Osram driver and Cree led are used for Slim Generation 2 series flood light. With strict quality control, 5 years warranty is offered. And lumen maintenance after 5 years will be more than 80%



*Cree LED
Osram Driver*



.....
Die-cast Housing
IP65 IK08
Surge Protection 6KV
.....

Plug-In
Sensor



Standard
Flood light



10 secs

Sensor
Flood Light



More Than Good



Cree LED



Osram Driver

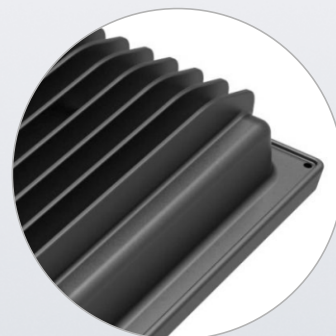

Die-Cast Heatsink



Features

Housing: Die-cast Aluminum ADC12
 Thermal Conductivity: 96 W/m·K
 Led: Philips
 CRI: Ra>70 (80/90 for option)
 SDCM: <6
 Power Factor: >0.95
 THD: <15
 Driver: Tureful
 Driver Efficiency: >90%
 Protection: OTP, OCP, OVP, SCP
 Surge Protection: 4KV
 Waterproof: IP65
 Impact Test: IK08
 Electrical: 100-277V, 50/60Hz
 Operating Temperature: -25~45°C
 Tm21: L80B10>50,000H
 Lifetime: 50,000H

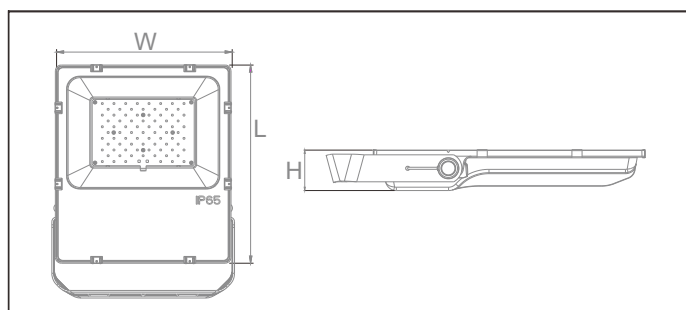

Functions

ZigBee · PWM · DALI · 0/1~10V · Micro-wave · PIR

Optical options:

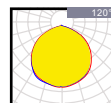

Model	Watt	Voltage	Lumen	CRI	IP	Dimension
FL010SECC-PT	10W	100~277V	1000LM	>70 (80)	IP65	L107*W140*H32MM
FL020SECC-PT	20W	100~277V	2000LM	>70 (80)	IP65	L190*W152*H40MM
FL030SECC-PT	30W	100~277V	3000LM	>70 (80)	IP65	L265*W220*H47.5MM
FL050SECC-PT	50W	100~277V	5000LM	>70 (80)	IP65	L300*W245*H49.5MM



Features

Housing: Die-cast Aluminum ADC12
 Thermal Conductivity: 96 W/m·K
 Led: Cree
 CRI: Ra>70 (80/90 for option)
 SDCM: <6
 Power Factor: >0.95
 THD: <15
 Driver: Osram
 Driver Efficiency: >90%
 Protection: OTP, OCP, OVP, SCP
 Surge Protection: 6KV
 Waterproof: IP65
 Impact Test: IK08
 Electrical: 220-240V, 50/60Hz
 Operating Temperature: -40~50°C
 Tm21: L80B10>50,000H
 Lifetime: 50,000H

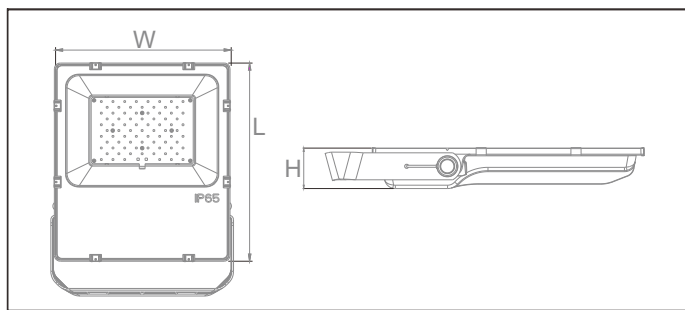

Functions

ZigBee · PWM · DALI · 0/1~10V · Micro-wave · PIR

Optical options:

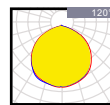

Model	Watt	Voltage	Lumen	CRI	IP	Dimension
FL070SEGH-CO	70W	220~240V	10500LM	>70 (80)	IP65	L354.5*W245*H55MM
FL100SEGH-CO	100W	220~240V	15000LM	>70 (80)	IP65	L402.5*W295*H60MM
FL150SEGH-CO	150W	220~240V	22500LM	>70 (80)	IP65	L430.5*W330*H60MM
FL200SEGH-CO	200W	220~240V	30000LM	>70 (80)	IP65	L470.5*W360*H60MM

Plug-in Sensor

With connectors on the standard floodlight, the sensor can be plugged into the fixture very easily, to realize Micro-wave or PIR sensor function. The female and male connectors are specially made to get waterproof IP65.

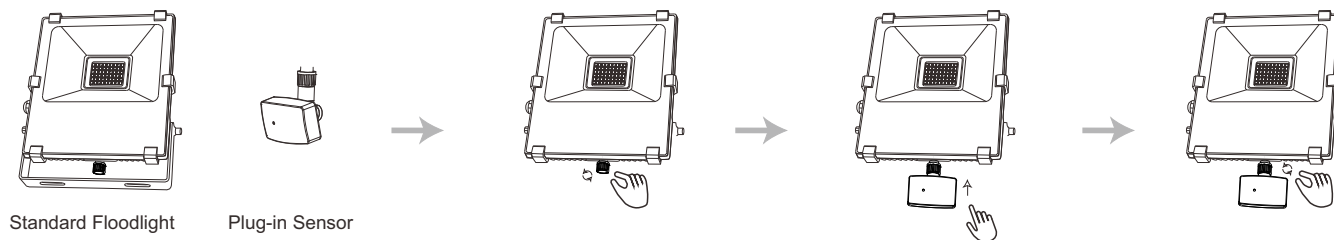

1 With sufficient light, the lamp doesn't switch on.



2 With insufficient ambient light, the sensor switches on the lamp when motion is detected.



3 After hold time, the sensor switches off the lamp when no motion is detected.

Micro-wave

Power Sourcing: 220V/AC-240V/AC	Detection Range: 180°
Power Frequency: 50Hz	Detection Distance: 2-12m (radius) adjustable
Ambient Light: 3-2000LUX (Adjustable)	HF System: 5.8GHz CW radar, ISM band
Time-Delay: Min.:10sec±3sec Max.:15min±2min	Transmission Power: <10mW
Power Consumption: 0.9W	Installing Height: 1.5m~3.5m
Rated Load: 300Wmax	Detection Motion Speed: 0.6~1.5m/s

Setting

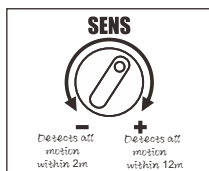

SENS Adjustment

SENS Knob controls the sensitivity, the detection area
Turn the sensor SENS knob counter-clockwise to decrease the sensitivity to lowest level=within 2m, and to the highest level=within 12meters

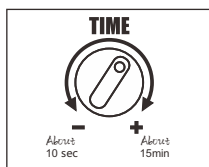

TIME Adjustment

LUX knob determines how long the floodlight will stay on after the last motion has been detected
Turn the sensor TIME knob counter-clockwise to decrease the time to 10 sec.
Turn the sensor TIME knob counter-clockwise to increase the time to 15 min.



LUX Adjustment

LUX knob determines at what light level the floodlight will start working. It is actually controlled by built-in light sensor
Turn the sensor LUX knob counter-clockwise to the moon(dusk) setting. In this provisional setting model, the sensor remains inactive during daylight. At dusk when you find it is the desired night level to start work, then simply set it to the position it needs to become operative as daylight declines

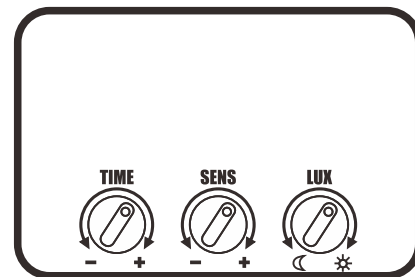

Power Sourcing: 220V/AC-240V/AC	Detection Range: 120°
Power Frequency: 50Hz	Detection Distance: 2-10m (<24°C) (adjustable)
Ambient Light: 3-2000LUX (Adjustable)	HF System: 5.8GHz CW radar, ISM band
Time-Delay: Min.:10sec±3sec Max.:7min±2min	Transmission Power: <10mW
Power Consumption: 0.9W	Installation Height: 1.8m~2.5m
Rated Load: 200Wmax	Detection Motion Speed: 0.6~1.5m/s
Working Humidity: <93%RH	Working Temperature: -20~+40°C

Setting

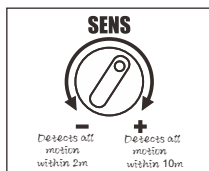

SENS Adjustment

SENS Knob controls the sensitivity, the detection area
Turn the sensor SENS knob counter-clockwise to decrease the sensitivity to lowest level=within 2m, and to the highest level=within 10meters

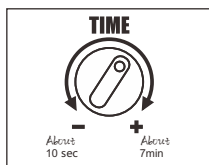

TIME Adjustment

LUX knob determines how long the floodlight will stay on after the last motion has been detected
Turn the sensor TIME knob counter-clockwise to decrease the time to 10 sec.
Turn the sensor TIME knob counter-clockwise to increase the time to 7 min.



LUX Adjustment

LUX knob determines at what light level the floodlight will start working. It is actually controlled by built-in light sensor
Turn the sensor LUX knob counter-clockwise to the moon(dusk) setting. In this provisional setting model, the sensor remains inactive during daylight. At dusk when you find it is the desired night level to start work, then simply set it to the position it needs to become operative as daylight declines

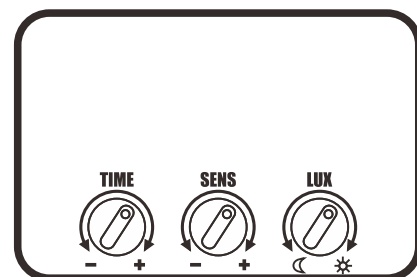

Note

PROBLEMS AND SOLVED WAY :

- ✂ The load do not work:
 - a. please check if the connection-wiring of power and load is correct.
 - b. please check if the load is good.
 - c. please check if the working light set correspond to ambient light.
- ✂ The sensitivity is poor:
 - a. Please check if there has hinder in front of the detection window to effect to receive the signal.
 - b. Please check if the ambient temperature is too high.
 - c. Please check if the induction signal source is in the detection fields.
 - d. Please check if the installation height corresponds to the height showed in the instruction.
 - e. Please check if the moving orientation is correct.
- ✂ The sensor can not shut off the load automatically:
 - a. Please check if there is continual signal in the detection field.
 - b. Please check if the time delay is the longest.
 - c. Please check if the power corresponds to the instruction.
- d. Please check if the temperature near the sensor changes obviously, such as air condition or central heating etc.

Packing

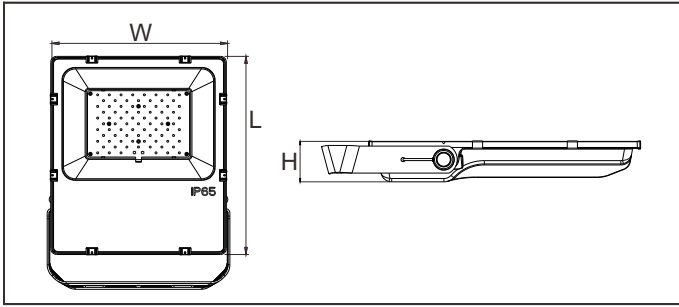

Model	Dimension(mm)	Inner Carton(mm)			QTY / Inner CTN	Outer Carton(mm)			QTY / Outer CTN	NW/CTN	GW/CTN
FL010SECC-PT	107*140*32	204	138	40	1	415	210	290	20	12.00	13.50
FL020SECC-PT	190*152*40	250	178	47	1	475	265	205	10	9.00	10.50
FL030SECC-PT	265*220*47.5	265	200	50	1	510	280	225	10	11.00	12.60
FL050SECC-PT	300*245*49.5	350	255	57	1	365	300	275	5	10.50	11.80

Model	Dimension(mm)	Inner Carton(mm)			QTY / Inner CTN	Outer Carton(mm)			QTY / Outer CTN	NW/CTN	GW/CTN
FL070SEGH-CM	354.5*245*55					435	340	130	1	3.20	4.30
FL100SEGH-CM	402.5*295*60					480	390	135	1	4.00	5.40
FL150SEGH-CM	430.5*330*60					510	435	135	1	5.10	6.70
FL200SEGH-CM	470.5*360*60					555	460	135	1	5.90	7.50